

TYPICAL NUMERIC QUESTIONS FOR PHYSICS I REGULAR

QUESTIONS TAKEN FROM CUTNELL AND JOHNSON

CONTENT STANDARD IB, IE

MOTION

1. Which one of the following expressions may be used to correctly find the angle θ in the drawing?

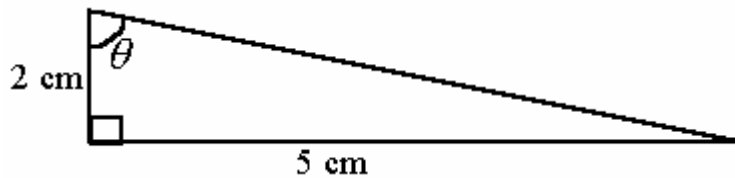

- A) $\theta = \cos^{-1}\left(\frac{5}{2}\right)$
- B) $\theta = \tan^{-1}\left(\frac{5}{2}\right)$
- C) $\theta = \sin^{-1}\left(\frac{2}{5}\right)$
- D) $\theta = \tan^{-1}\left(\frac{2}{5}\right)$
- E) $\theta = \sin^{-1}\left(\frac{5}{2}\right)$

2. The length of each side of a square is 4.0 m. What is the length of the diagonal of the square (shown as a dashed line in the figure)?

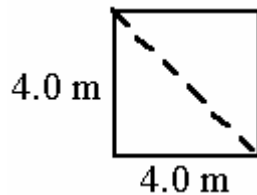

- A) 2.8 m B) 3.5 m C) 5.7 m D) 8.0 m E) 16 m

3. Which one of the following choices is a vector quantity?
 A) mass B) temperature C) time D) displacement E) volume
4. What is the angle between the vectors \mathbf{A} and $-\mathbf{A}$ when they are drawn from a common origin?
 A) 0° B) 90° C) 180° D) 270° E) 360°
5. A displacement vector has a magnitude of 810 m and points at an angle of 18° above the positive x axis. What are the x and y scalar components of this vector?
- | | <i>x scalar component</i> | <i>y scalar component</i> |
|----|---------------------------|---------------------------|
| A) | 770 m | 250 m |
| B) | 560 m | 585 m |
| C) | 585 m | 560 m |
| D) | 250 m | 750 m |
| E) | 713 m | 385 m |
6. A displacement vector is 23 km in length and is directed 65° south of east. What are the components of this vector?
- | | <i>Eastward Component</i> | <i>Southward Component</i> |
|----|---------------------------|----------------------------|
| A) | 21 km | 9.7 km |
| B) | 23 km | 23 km |
| C) | 23 km | 0 km |
| D) | 9.7 km | 21 km |
| E) | 0 km | 23 km |

Use the following to answer question 7:

The table gives the x and y components of two vectors \mathbf{A} and \mathbf{B} :

Vector	x component	y component
A	+15 units	+10 units
B	+15 units	-10 units

7. Determine the magnitude of the vector sum $\mathbf{A} + \mathbf{B}$.
 A) 5 units B) 15 units C) 20 units D) 30 units E) 50 units

Use the following to answer question 8:

A racecar, traveling at constant speed, makes one lap around a circular track of radius r in a time t . Note: The circumference of a circle is given by $C = 2\pi r$.

8. When the car has traveled halfway around the track, what is the magnitude of its *displacement* from the starting point?
A) r B) $2r$ C) πr D) $2\pi r$ E) zero meters

9. An elevator is moving upward with a speed of 11 m/s. Three seconds later, the elevator is still moving upward, but its speed has been reduced to 5.0 m/s. What is the average acceleration of the elevator during the 3.0 s interval?
A) 2.0 m/s^2 , downward D) 5.3 m/s^2 , upward
B) 2.0 m/s^2 , upward E) 2.7 m/s^2 , downward
C) 5.3 m/s^2 , downward

10. A car, starting from rest, accelerates in a straight-line path at a constant rate of 2.5 m/s^2 . How far will the car travel in 12 seconds?
A) 180 m B) 120 m C) 30 m D) 15 m E) 4.8 m

11. A body initially at rest is accelerated at a constant rate for 5.0 seconds in the positive x direction. If the final speed of the body is 20.0 m/s, what was the body's acceleration?
A) 0.25 m/s^2 B) 2.0 m/s^2 C) 4.0 m/s^2 D) 9.8 m/s^2 E) 1.6 m/s^2

12. A racecar has a speed of 80 m/s when the driver releases a drag parachute. If the parachute causes a deceleration of -4 m/s^2 , how far will the car travel before it stops?
A) 20 m B) 200 m C) 400 m D) 800 m E) 1000 m

Use the following to answer questions 13-14:

An object starts from rest and accelerates uniformly in a straight line in the positive x direction. After 11 seconds, its speed is 70.0 m/s.

13. Determine the acceleration of the object.
A) $+3.5 \text{ m/s}^2$ B) $+6.4 \text{ m/s}^2$ C) -3.5 m/s^2 D) -6.4 m/s^2 E) $+7.7 \text{ m/s}^2$

14. How far does the object travel during the first 11 seconds?
A) 35 m B) 77 m C) 390 m D) 590 m E) 770 m

15. A brick is dropped from rest from a height of 4.9 m. How long does it take for the brick to reach the ground?
A) 0.6 s B) 1.0 s C) 1.2 s D) 1.4 s E) 2.0 s
16. A ball is dropped from rest from a tower and strikes the ground 125 m below. Approximately how many seconds does it take for the ball to strike the ground after being dropped? Neglect air resistance.
A) 2.50 s B) 3.50 s C) 5.05 s D) 12.5 s E) 16.0 s
17. Water drips from rest from a leaf that is 20 meters above the ground. Neglecting air resistance, what is the speed of each water drop when it hits the ground?
A) 10 m/s B) 15 m/s C) 20 m/s D) 30 m/s E) 40 m/s
18. What maximum height will be reached by a stone thrown straight up with an initial speed of 35 m/s?
A) 98 m B) 160 m C) 41 m D) 62 m E) 18 m

Use the following to answer questions 19-20:

A ball is shot straight up from the surface of the earth with an initial speed of 19.6 m/s. Neglect any effects due to air resistance.

19. What maximum height will the ball reach?
A) 9.80 m B) 14.7 m C) 19.6 m D) 24.5 m E) 58.8 m
20. How much time elapses between the throwing of the ball and its return to the original launch point?
A) 4.00 s B) 2.00 s C) 12.0 s D) 8.00 s E) 16.0 s

Use the following to answer questions 21-22:

A projectile is fired at an angle of 60.0° above the horizontal with an initial speed of 30.0 m/s.

21. What is the magnitude of the *horizontal* component of the projectile's displacement at the end of 2 s?
A) 30 m B) 40 m C) 10 m D) 20 m E) 50 m
22. How long does it take the projectile to reach the highest point in its trajectory?
A) 1.5 s B) 2.7 s C) 4.0 s D) 6.2 s E) 9.8 s

Use the following to answer questions 23-24:

A projectile is fired from a gun and has initial horizontal and vertical components of velocity equal to 30 m/s and 40 m/s, respectively.

23. Determine the initial speed of the projectile.
A) 40 m/s B) 50 m/s C) 60 m/s D) 70 m/s E) 80 m/s
24. At what angle is the projectile fired (measured with respect to the horizontal)?
A) 37° B) 40° C) 45° D) 53° E) 60°
25. A projectile is fired horizontally with an initial speed of 57 m/s. What are the horizontal and vertical components of its displacement 3.0 s after it is fired?
- | | <u>horizontal</u> | <u>vertical</u> |
|----|-------------------|-----------------|
| A) | 44 m | 29 m |
| B) | 170 m | 29 m |
| C) | 170 m | 44 m |
| D) | 210 m | 44 m |
| E) | 210 m | 0 m |
26. A quarterback throws a pass at an angle of 35° above the horizontal with an initial speed of 25 m/s. The ball is caught by the receiver 2.55 seconds later. Determine the distance the ball was thrown.
A) 13 m B) 18 m C) 36 m D) 52 m E) 72 m

Use the following to answer question 27:

A shell is fired with a horizontal velocity in the positive x direction from the top of an 80 m high cliff. The shell strikes the ground 1330 m from the base of the cliff.

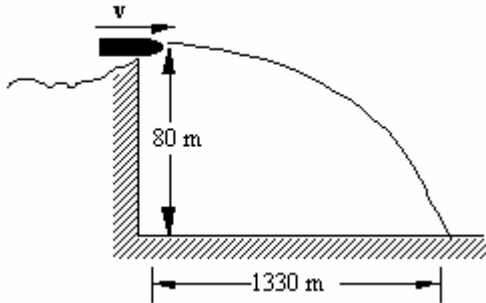

27. What is the speed of the shell as it hits the ground?
A) 4.0 m/s B) 9.8 m/s C) 82 m/s D) 170 m/s E) 330 m/s
28. A cannonball is aimed 30.0° above the horizontal and is fired with an initial speed of 125 m/s at ground level. How far away from the cannon will the cannonball hit the ground?
A) 125 m
B) 138 m
C) 695 m
D) 1040 m
E) 1380 m
29. An arrow is shot horizontally from a height of 4.9 m above the ground. The initial speed of the arrow is 45 m/s. Neglecting friction, how long will it take the arrow to hit the ground?
A) 9.2 s B) 6.0 s C) 1.0 s D) 1.4 s E) 4.6 s

Use the following to answer questions 30-31:

A football is kicked with a speed of 18 m/s at an angle of 65° to the horizontal.

30. What are the respective *horizontal* and *vertical* components of the initial velocity of the football?
- A) 7.6 m/s, 16 m/s D) 13 m/s, 8.4 m/s
B) 16 m/s, 7.6 m/s E) 9 m/s, 9 m/s
C) 8.4 m/s, 13 m/s
31. How far does the football travel *horizontally* before it hits the ground?
- A) 18 m B) 25 m C) 36 m D) 48 m E) 72 m

Use the following to answer question 32:

A rock is kicked *horizontally* at a speed of 10 m/s from the edge of a cliff. The rock strikes the ground 55 m from the foot of the cliff of height H as suggested in the figure. Neglect air resistance.

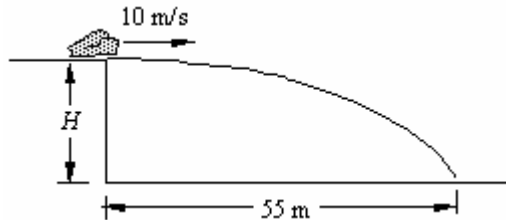

32. How long is the rock in the air?
- A) 1.0 s B) 1.2 s C) 3.4 s D) 5.5 s E) 11.2 s

Use the following to answer question 33:

A projectile is fired horizontally with an initial speed of 50.0 m/s. Neglect air resistance.

33. What is the magnitude of the acceleration of the projectile 3.00 s after it is fired?
- A) 9.8 m/s^2 B) 16.6 m/s^2 C) 29.4 m/s^2 D) 5.42 m/s^2 E) 4.07 m/s^2